

VG MAB

VG1-0306-005M-MAB

The VG-MAB booster set features one stainless steel multistage pump mounted on a powder-coated steel base plate. The pump is controlled by our advanced MAB variable speed control panel.

PRODUCT FEATURES

- Variable speed pump control
- 304 stainless steel pump
- 24-litre pressure vessel(s) with flow through isolation and drain valve
- Air-cooled inverters
- BMS volt-free contacts
- External enable on/off
- Hand/off/auto switches
- External low water
- Dry run protection
- Glycerine filled pressure gauge
- Pump check valve

APPLICATIONS

Cold water pressure and flow boosting in a range of domestic, commercial and industrial applications.

PRODUCT DATA SHEET



Specification

Suction connection	1"
Discharge connection	1"
Maximum working pressure	10.00 bar
Motor power	0.50 kW
Weight	40.00 kg
Vessel size	24.0 L
Number of pumps	1

Performance

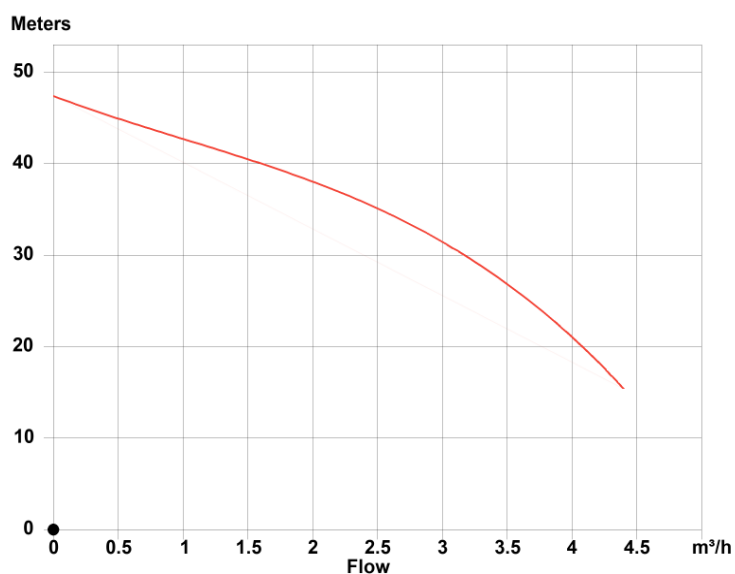

Electrical Data

Mains connection	1~ 230V/50Hz
Current per Pump	3,1 A

Model Codes

VG1-0306-005M-MAB

Range

No of Pumps

Nominal flow in m³/h

Motor kW per Pump

Control type

Technical Drawings

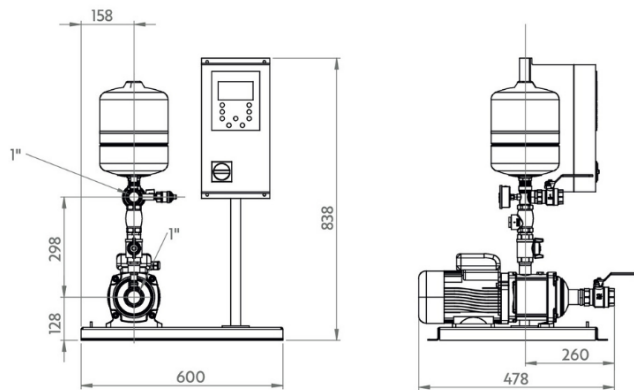

Drawing dimensions

Dimension A	600 mm
Dimension B	530 mm
Dimension C	838 mm

Performance

