

## VG MAB

### VG1-0308-007M-MAB

The VG-MAB booster set features one stainless steel multistage pump mounted on a powder-coated steel base plate. The pump is controlled by our advanced MAB variable speed control panel.

#### PRODUCT FEATURES

- Variable speed pump control
- 304 stainless steel pump
- 24-litre pressure vessel(s) with flow through isolation and drain valve
- Air-cooled inverters
- BMS volt-free contacts
- External enable on/off
- Hand/off/auto switches
- External low water
- Dry run protection
- Glycerine filled pressure gauge
- Pump check valve

#### APPLICATIONS

Cold water pressure and flow boosting in a range of domestic, commercial and industrial applications.

## PRODUCT DATA SHEET



#### Specification

<b>Suction connection</b>	1"
<b>Discharge connection</b>	1"
<b>Maximum working pressure</b>	10.00 bar
	0.75 kW
<b>Weight_incl_Fittings</b>	41.00 kg
<b>Vessel_Size</b>	24.0 L
<b>Number of pumps</b>	1

#### Performance

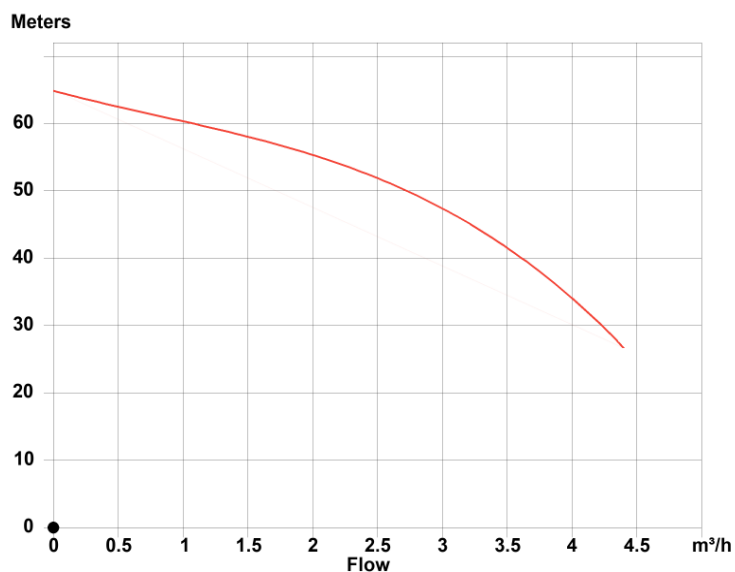

## Electrical Data

<b>Mains connection</b>	1~ 230V/50Hz
<b>Current per Pump</b>	4,4 A

## Model Codes

VG1-0308-007M-MAB

Range

No of Pumps

Nominal flow in m<sup>3</sup>/h

Motor kW per Pump

Control type

## Technical Drawings

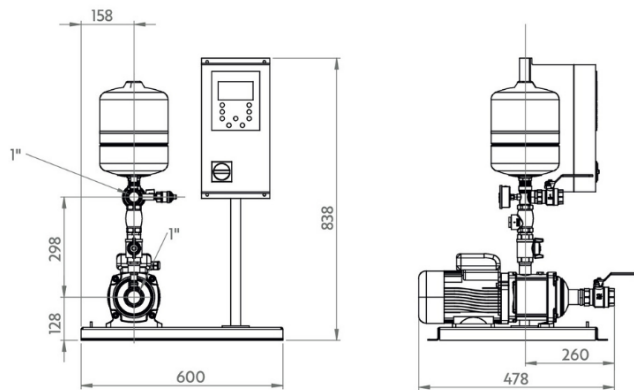

## Drawing dimensions

<b>Dimension A</b>	600 mm
<b>Dimension B</b>	478 mm
<b>Dimension C</b>	838 mm

Performance

---

